

# Studica<sup>®</sup> ROBOTICS

*Build Better Robots<sup>®</sup>*

Studica Starter Bot 2026 / 2027 Build Guide

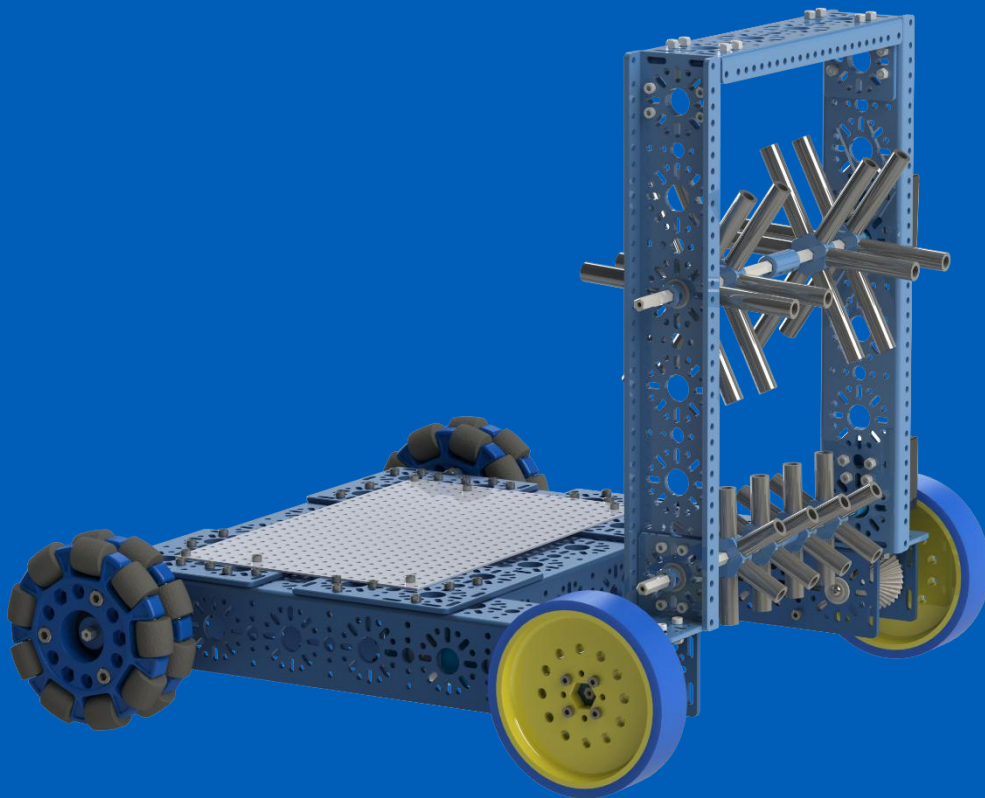

© Copyright 2026, Studica Limited, All rights reserved.

No part of this publication may be reproduced, distributed, or transmitted in any form or by any means, including photocopying, recording, or other electronic or mechanical methods, without the prior written permission of Studica Limited.

All other trademarks cited herein are the property of their respective owners.



# Document History

Release	Date	Note
0.1	04 May 2026	<ul style="list-style-type: none"><li>• After Champs Release</li></ul>

# Welcome to the 2026/2027 Season

Studica is excited to offer this starter bot to all teams competing or not competing in the FTC 2026/2027 season. We wish all teams the best and hope everyone has a great experience this year.

This guide was designed for a rookie starter bot but can be used by more developed teams. More developed teams might find purchasing other kits, such as the FTC Drive Base V2 or the soon-to-be V3, a better option.

All FTC teams are encouraged to register their FTC accounts with our US office and receive a 25% discount on most FTC-related products. There are also grant programs that teams can apply for. We are excited to share that we now offer structure in a variety of colors. Structure samples are also available. Please check out <https://www.studica.com/first-tech-challenge> for more information.

# Table of Contents

Drive Base .....	7
Tools Required.....	7
Step 1: .....	8
Step 2: .....	9
Step 3: .....	10
Step 4: .....	11
Step 5: .....	12
Step 6: .....	13
Step 7: .....	14
Step 8: .....	16
Step 9: .....	17
Step 10: .....	18
Step 11: .....	19
Step 12: .....	20
Step 13: .....	21
Step 14: .....	22
Step 15: .....	23
.....	24
Step 16: .....	24
Step 17: .....	25
Step 18: .....	26
Step 19: .....	27
Step 20: .....	28
Step 21: .....	29
Step 22: .....	30
Step 23: .....	31
Step 23: .....	32
Step 24: .....	33
Step 25: .....	34

# Drive Base

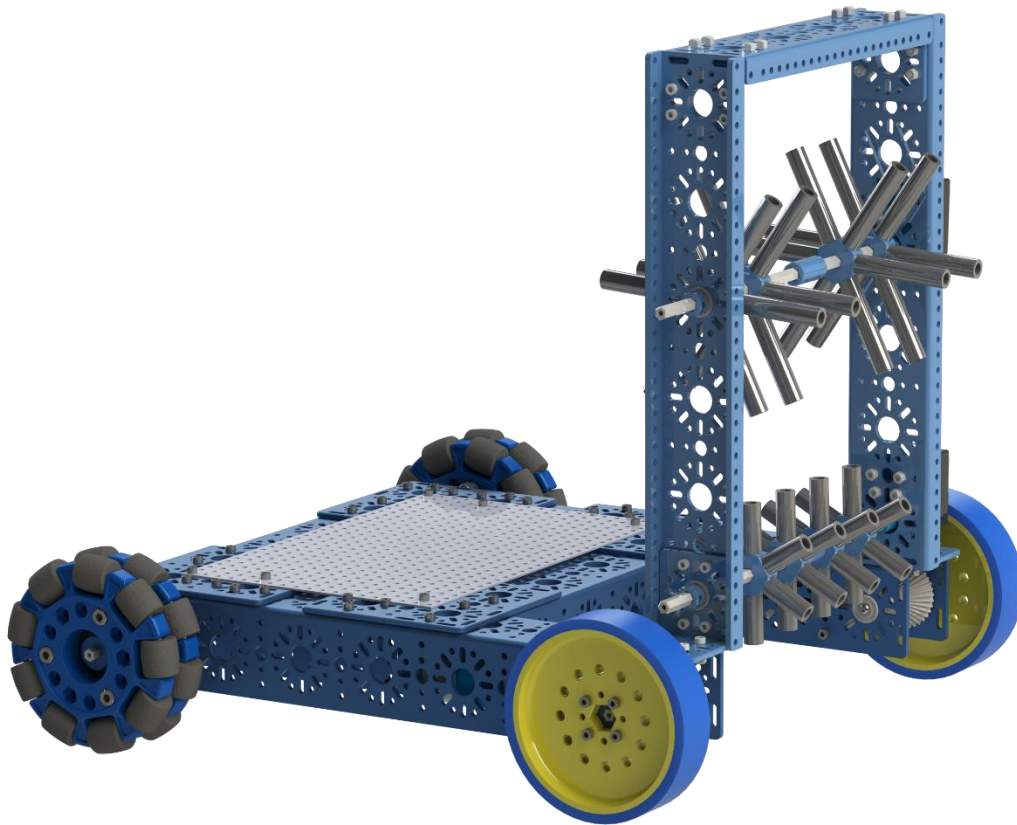

## Tools Required

- Hex Key Metric 7 Piece Set, Part # 70144-7
- Combination Wrench, Part # 70145
- 8mm Wrench, Part # 70901
- 5.5mm Nut Driver, Part # 70146
- Scissors (Not in Kit)

**CONTROL HUB NOT  
INCLUDED IN KIT**

## Step 1:

### Parts:

- 1 x Omni Wheel
- 3 x M5 x 40mm SHCS
- 2 x M4 x 8mm SHCS
- 3 x M5 Nyloc Nuts
- 3 mm Hex Key (Blue)
- 4 mm Hex Key (Yellow)
- 1 x Enhanced Wheel Hub

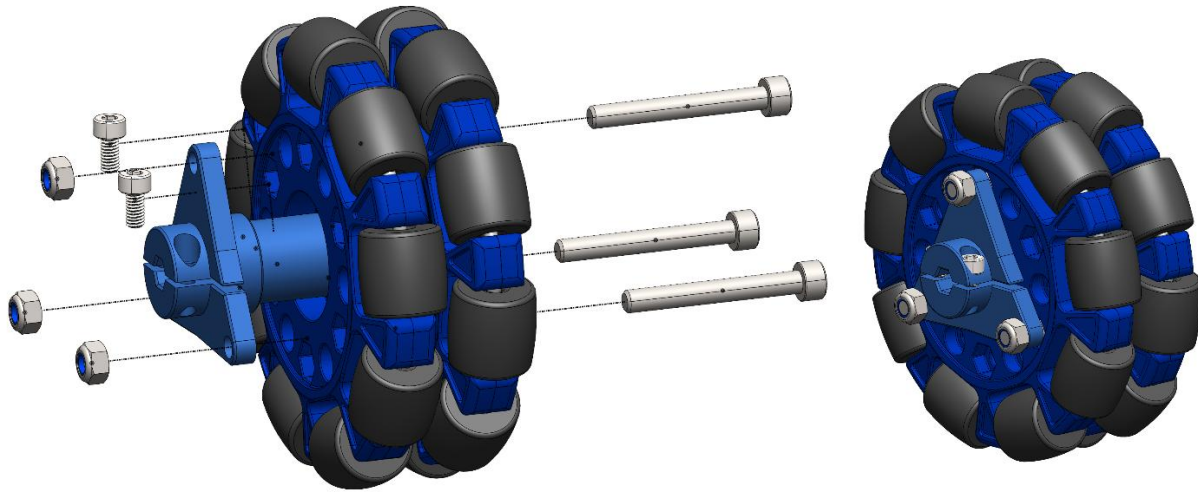

Using the blue 3mm hex key, screw the M4 x 8mm SHCS into the screw ports of the enhanced wheel hub clamping section. **NOTE TO DO NOT TIGHTEN THE SCREWS DOWN YET.** Using the M5 SHCS slot them through the Omni Wheel and into the Enhanced Wheel Hub. The socket head should be inside the cavity of the omni wheel screw area. Use your hand to lightly turn the M5 nyloc nuts on the M5 SHCS. Using the 8mm wrench and yellow 4mm hex key, fully tighten the screws into the nyloc nuts.

Repeat step 1 to create another Omni Wheel assembly.

## Step 2:

Parts:

- 1 x 336 mm U-Channel
- 1 x 192 mm U-Channel
- 1 x 90 Degree Bracket
- 8 x M3 x 12 SHCS
- 8 x M3 Nyloc Nuts
- 2.5 mm Hex Key (Green)
- 5.5 mm Nut Driver

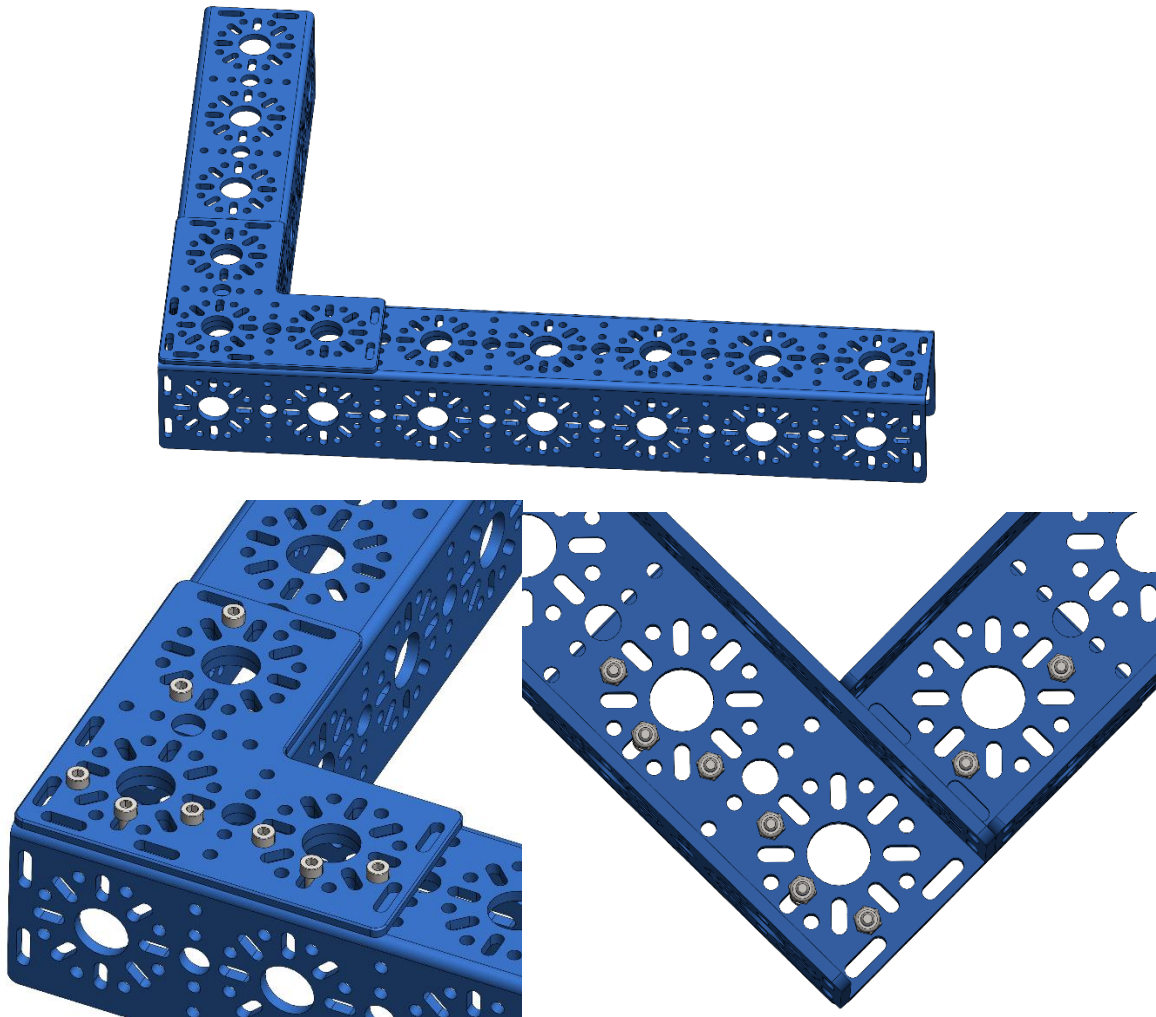

Using the green 2.5 mm hex key, screw the M3 x 12mm SHCS through the 90-degree bracket into the 336 mm U-Channel and 192mm U-Channel into M3 Nyloc nuts. Try to make sure that this is as square as possible. This can be completed by slowly tightening each screw in a circular pattern.

### Step 3:

Parts:

- 6 x M3 x 12mm SHCS
- 2.5mm Hex Key (Green)
- 5.5mm Nut Driver
- 1 x 336mm U-Channel
- 1 x 90 Degree Bracket
- Assembly from Step 2

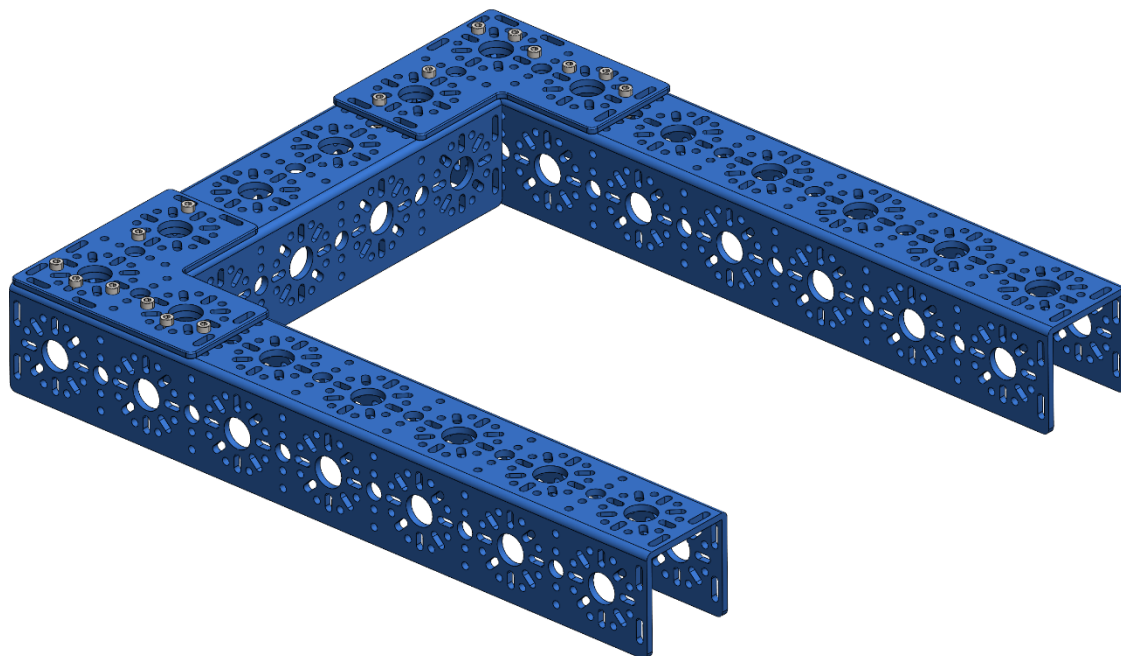

Repeat step 2 but for the other side of the 192mm U-Channel.

Side Tip: The squarer your drive base, the more accurate your movements in auto and teleop will be.

## Step 4:

### Parts:

- 1 x Assembly from step 3
- 2 x 90 Degree Bracket
- 1 x 192 mm U-Channel
- 12 x M3 x 12mm SHCS
- 12 x M3 Nyloc Nuts
- 1 x 2.5 mm Hex Key (Green)
- 1 x 5.5 mm Nut Driver

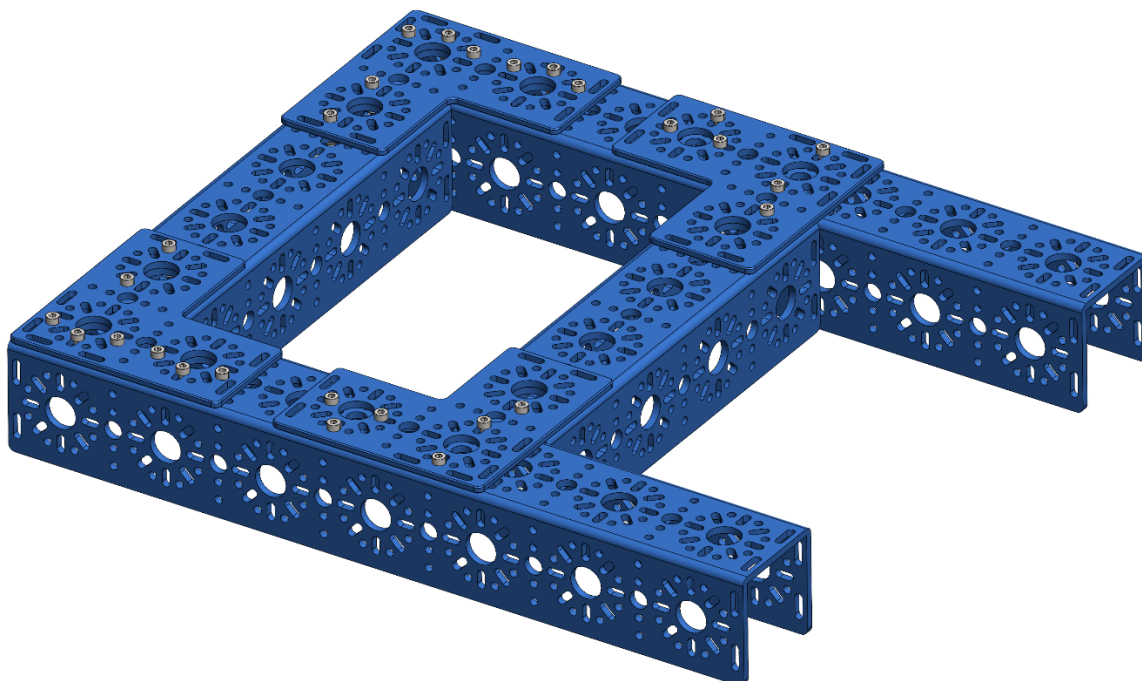

Repeat the similar process from step 2 and 3 for the middle section of the drive base. The 90 degree brackets middle 14mm hole should be over the 8mm hole of the 336mm U-Channel.

## Step 5:

Parts:

- 1 x Polycarbonate Sheet
- Scissors

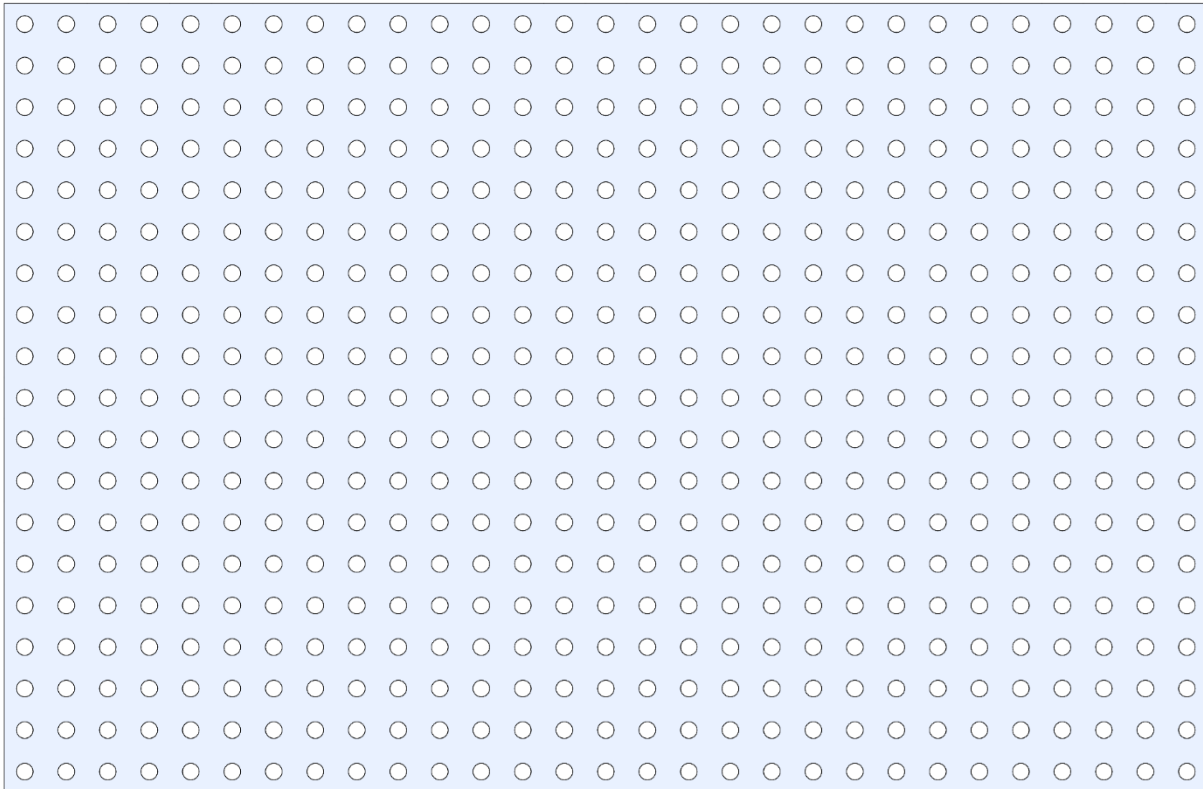

With one of the polycarbonate sheets count 29 holes and using scissors cut down the middle between the 29 and 30<sup>th</sup> hole. This should give you a 29 x 19 hole sheet.

## Step 6:

Parts:

- Assembly from Step 4
- Sheet from Step 5
- 6 x M3 x 12 mm SHCS
- 6 x M3 Nyloc
- 1 x 2.5mm Hex Key (Green)
- 1 x 5.5mm Nut Driver

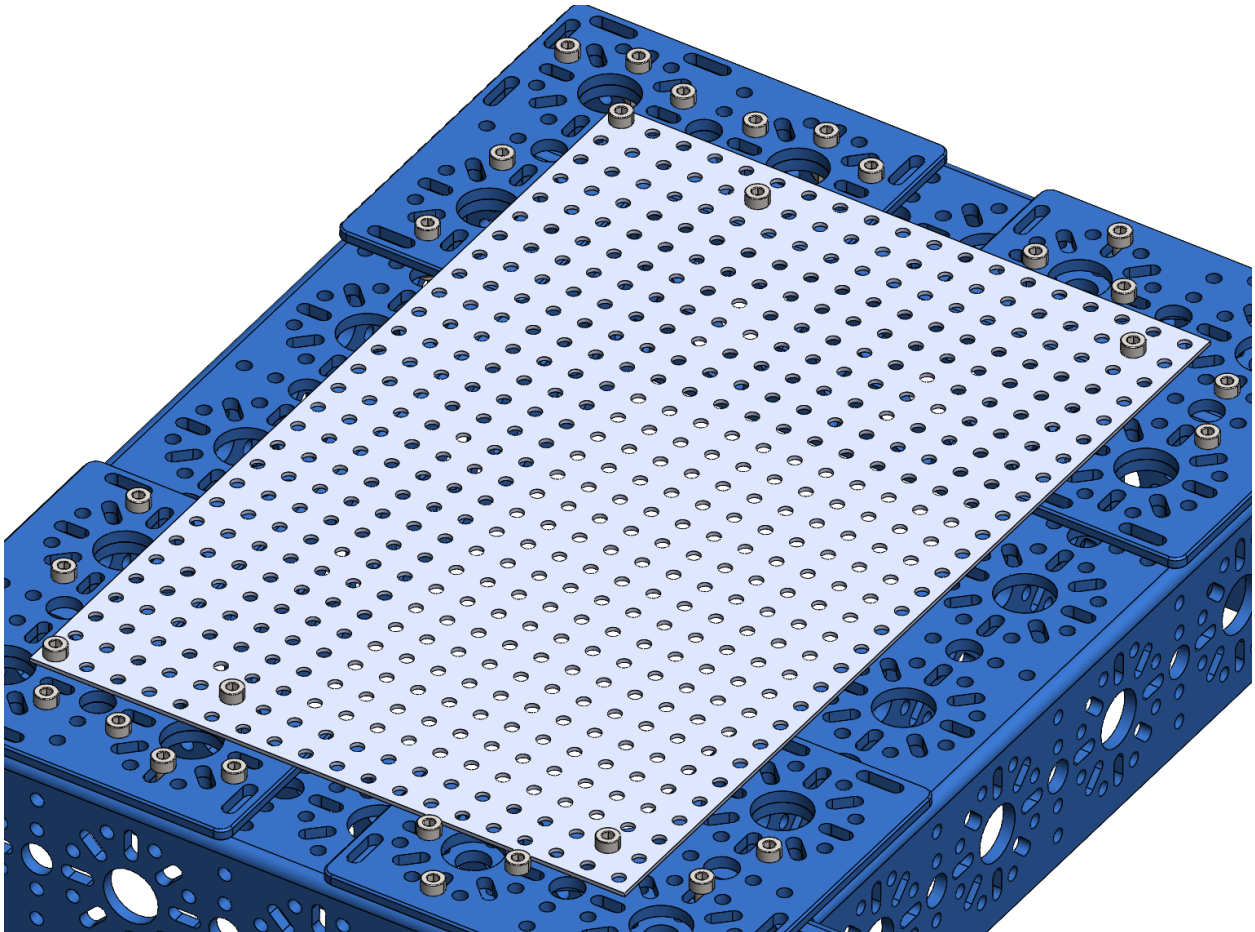

Using the 6 x M3 SHCS, screw the polycarbonate sheet into the drive base. The sheet will hold the control hub.

## Step 7:

### Parts:

- 1 x M3 x 10mm BHCS with blue thread lock pre-applied
- 1 x M3 Washer
- 1 x 96 mm Hex Shaft
- 2 x Flanged Bearing
- 1 x 2 mm Spacer
- 1 x 2mm Hex Key (Pink)
- 1 x 3mm Hex Key (Yellow)
- 1 x Omni Wheel assembly from step 1

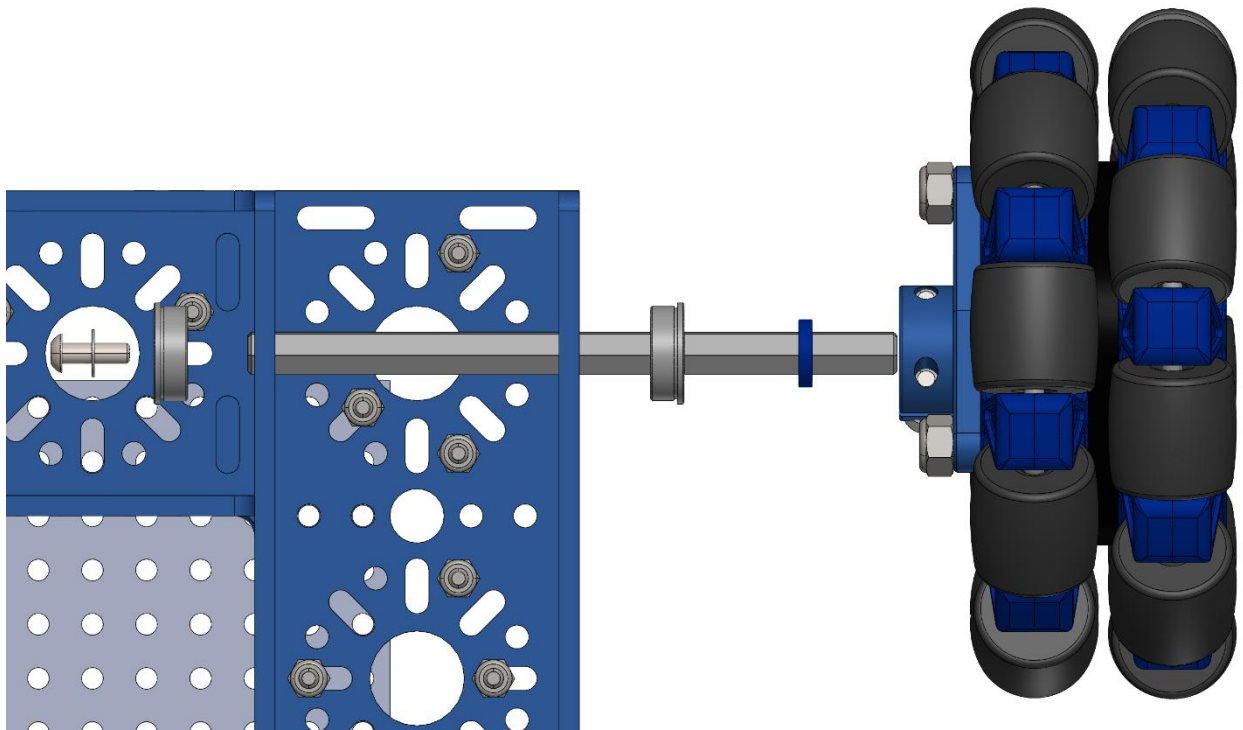

Above is the stack up of the omni wheel assembly on the robot drive base. For easy assembly first screw the special M3 x 10mm BHCS into one end of the hex shaft. Ensure the washer is placed between the hex shaft and the head of the BHCS as you are screwing it in. The thread locking compound on the screw will keep this screw locked into place.

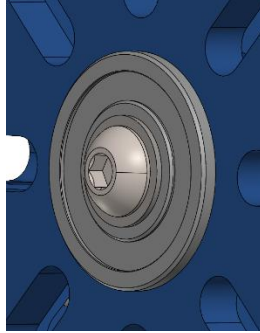

Slide the shaft from the inside of the 192mm U-Channel into a flanged bearing. On the outside of the base should be another bearing, spacer and the omni wheel assembly. When happy with the location, tighten the M4 screws on the omni wheel enhanced wheel hub to clamp the wheel to the shaft.

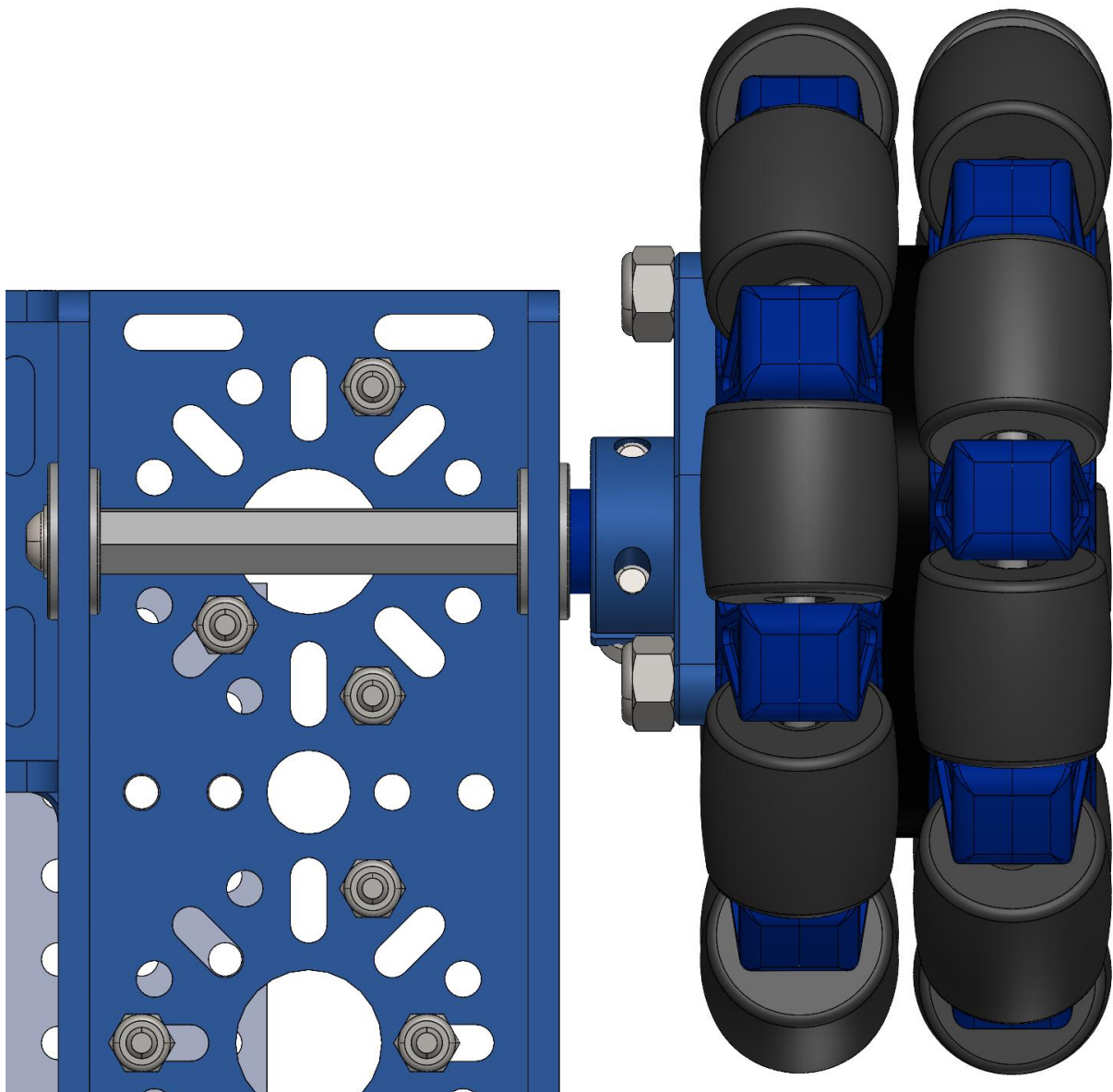

The wheel should be completely free spinning. To ensure it spins freely, spin the wheel with your hand. It should spin fast and for a long time, like a fidget spinner. If it does not spin freely you will need to loosen the M4 screws and reduce the tightness of the wheel against the spacer and bearing. Repeat until you can spin the wheel freely and fast.

## Step 8:

Parts:

- 1 x Omni wheel assembly from step 1
- 1 x Assembly from step 7
- 1 x M3 x 10mm BHCS with blue thread lock pre-applied
- 1 x M3 Washer
- 1 x 96 mm Hex Shaft
- 2 x Flanged Bearing
- 1 x 2 mm Spacer
- 1 x 2mm Hex Key (Pink)
- 1 x 3mm Hex Key (Yellow)

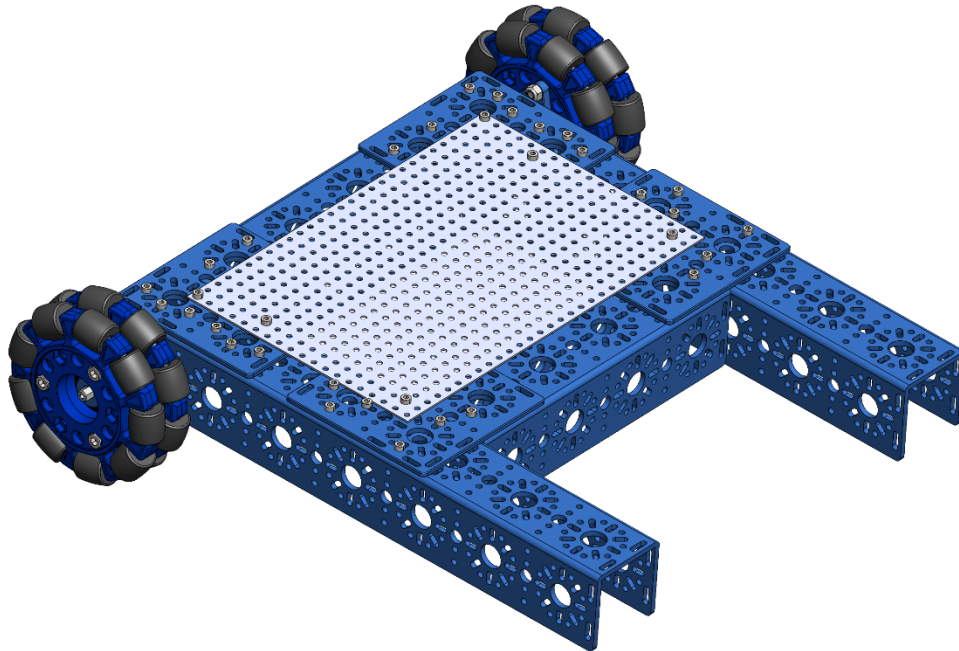

Repeat step 7 for the other side of the drive base. When complete you should have a robot that looks like the above picture.

## Step 9:

### Parts:

- 1 x M3 x 10mm BHCS with blue thread lock pre-applied
- 1 x M3 Washer
- 1 x 70 mm Hex Shaft
- 2 x Flanged Bearing
- 1 x 1 mm Spacer
- 1 x 2 mm Spacer
- 1 x 5 mm Spacer
- 1 x Clamping Shaft Hub
- 1 x 36T Bevel Gear
- 1 x 2mm Hex Key (Pink)
- 1 x 2.5mm Hex Key (Green)

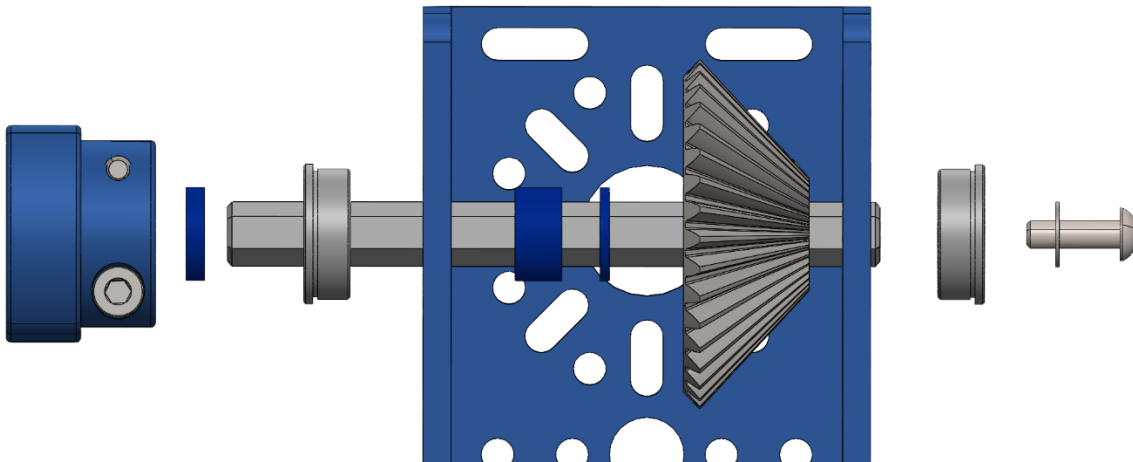

**NOTE: THE 36T BEVEL GEAR IS HELICAL AND HAS 2 GEARS IN EACH PACK. THE GEARS ARE TWISTED IN DIFFERENT DIRECTIONS. IT DOES NOT MATTER WHICH GEAR GOES WHERE IN THE SINGLE ASSEMBLY BUT YOU NEED ONE BENT ONE WAY AND ANOTHER BENT THE OTHER WAY FOR SUCCESSFUL MESH.**

This is for the front of the drive base where we will install the motors and the drive wheels for the robot. The stack up is shown above. As with step 7 and 8 we use a thread locked BHCS here with a washer. Also following step 7 and 8 make sure the shaft can spin freely.

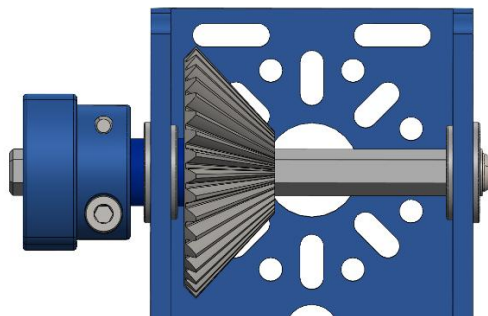

## Step 10:

### Parts:

- 1 x M3 x 10mm BHCS with blue thread lock pre-applied
- 1 x M3 Washer
- 1 x 70 mm Hex Shaft
- 2 x Flanged Bearing
- 1 x 1 mm Spacer
- 1 x 2 mm Spacer
- 1 x 5 mm Spacer
- 1 x Clamping Shaft Hub
- 1 x 36T Bevel Gear
- 1 x 2mm Hex Key (Pink)
- 1 x 2.5mm Hex Key (Green)

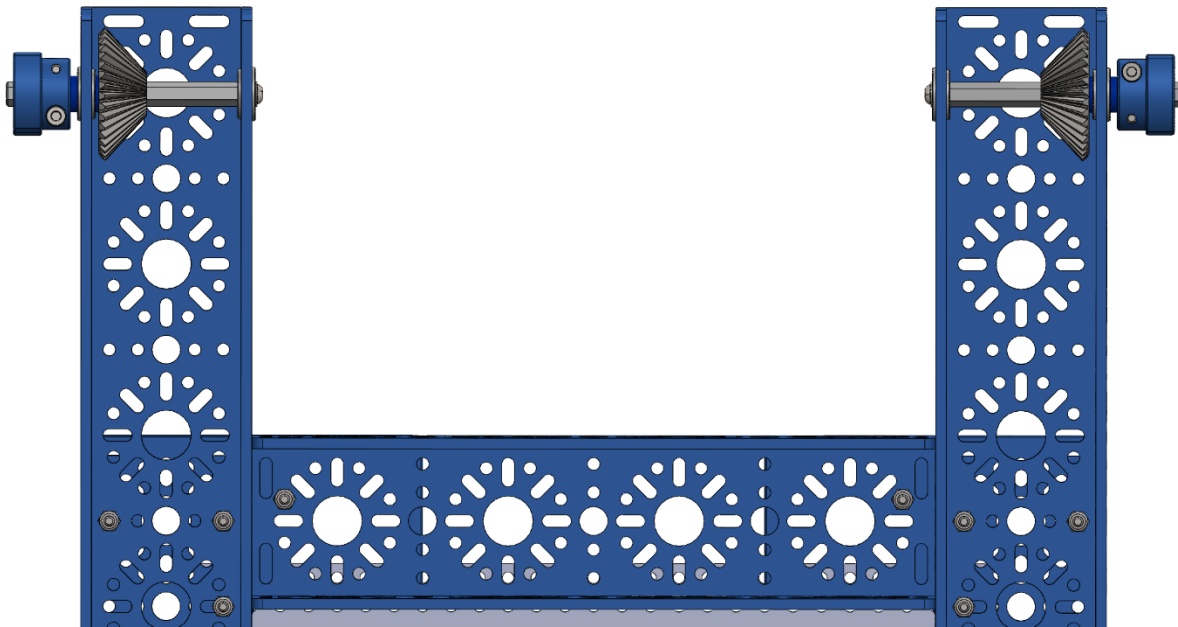

Repeat step 9 for the other side.

## Step 11:

### Parts:

- 2 x Maverick Motor with 50.9:1 Clover Gearbox
- 2 x Clover Mount
- 8 x M3 x 10mm SHCS
- 4 x 1mm Spacer
- 4 x 5mm Spacer
- 2 x 36T Bevel Gear
- 1 x 2.5 mm Hex Key (Green)

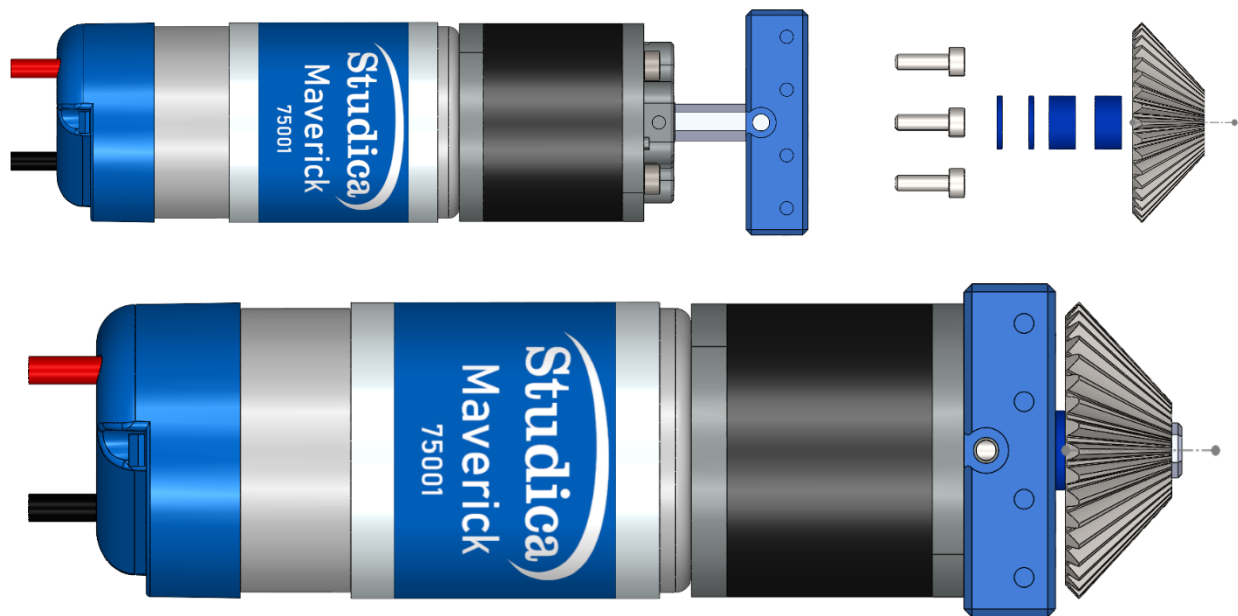

This step is for the motor assembly. Slide the motor into the clover mount. Use the SHCS to screw the motor into the clover mount. Slide the spacers and the bevel gear onto the shaft of the motor. **NOTE: THE BEVEL GEAR MUST BE THE OPPOSITE BEND OF THE BEVEL GEAR FROM STEP 9 and 10. THE BEVEL GEAR AND SPACERS WILL ALSO BE LOOSE UNTIL THE MOTOR IS ASSEMBLED IN THE CHANNEL AND CAN EASILY FALL OFF.**

Repeat this step again to have two motors.

## Step 12:

Parts:

- 1 x Motor Assembly from step 11
- 1 x Drive Base Assembly
- 4 x M3 x 10 mm SHCS
- 1 x 2.5 mm Hex Key (Green)

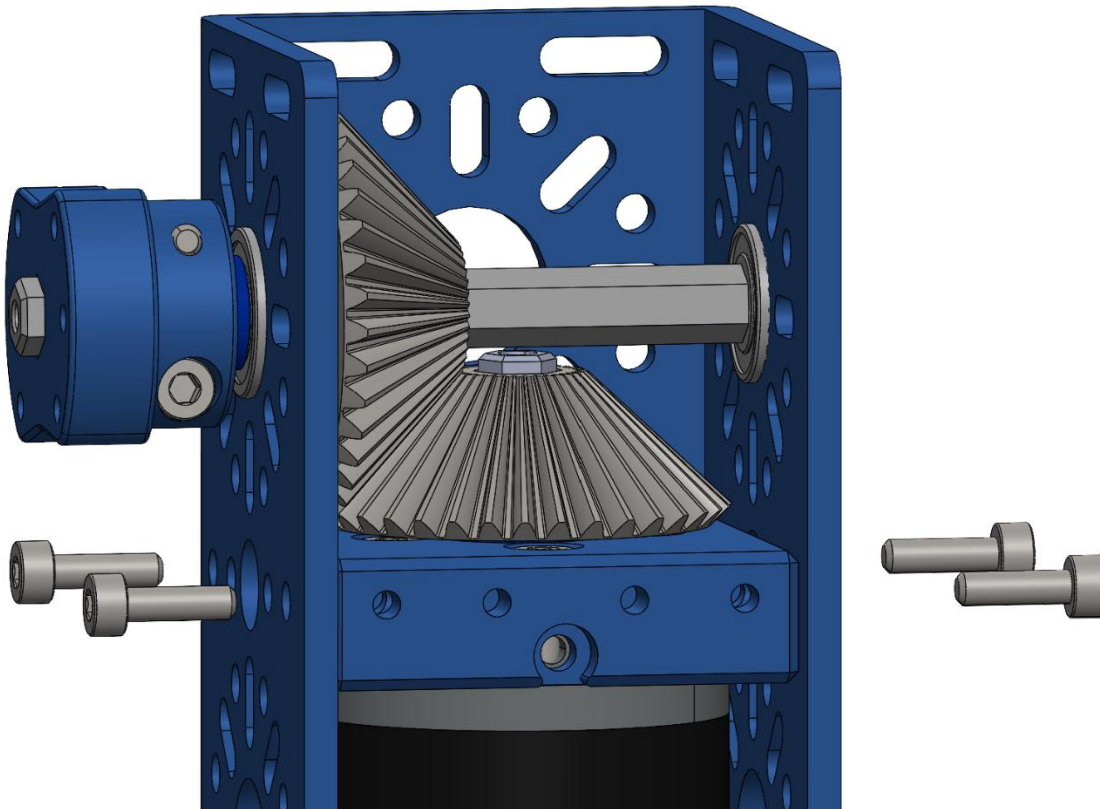
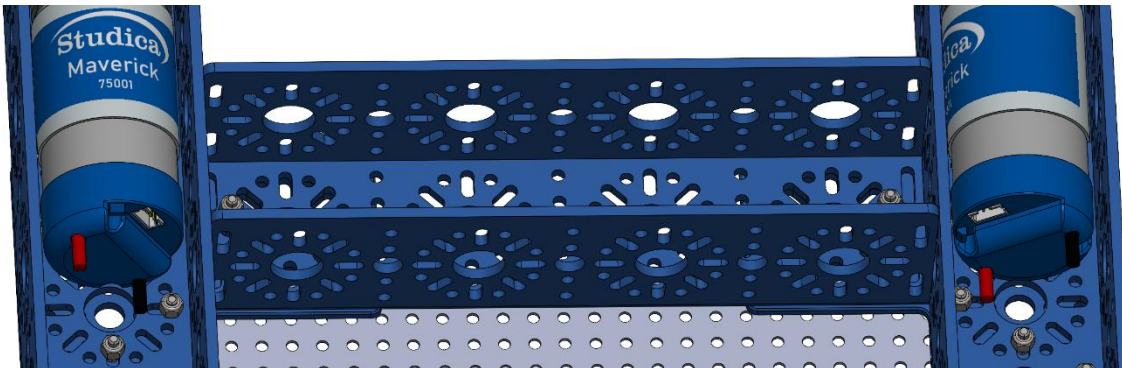

Ensure when putting the motor assembly into the channel the encoder port of the motor is easily accessible. Slide the motor into the bevel gear from steps 9 or 10 and secure with the SHCS.

## Step 13:

Parts:

- 1 x Drive Base Assembly
- 1 x Motor Assembly from step 11
- 4 x M3 x 10 mm SHCS
- 1 x 2.5 mm Hex Key (Green)

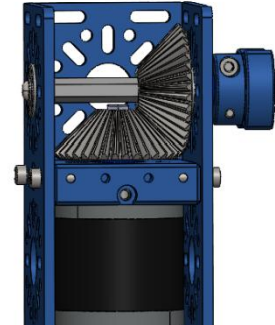
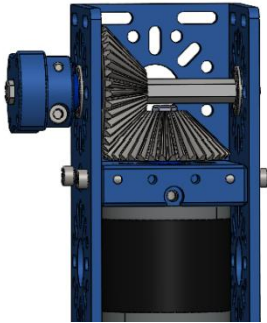

Repeat step 12 for the other side.

## Step 14:

Parts:

- 1 x Drive Base Assembly
- 2 x Drive Wheel
- 8 x M3 x 12 mm SHCS
- 1 x 2.5 mm Hex Key (Green)

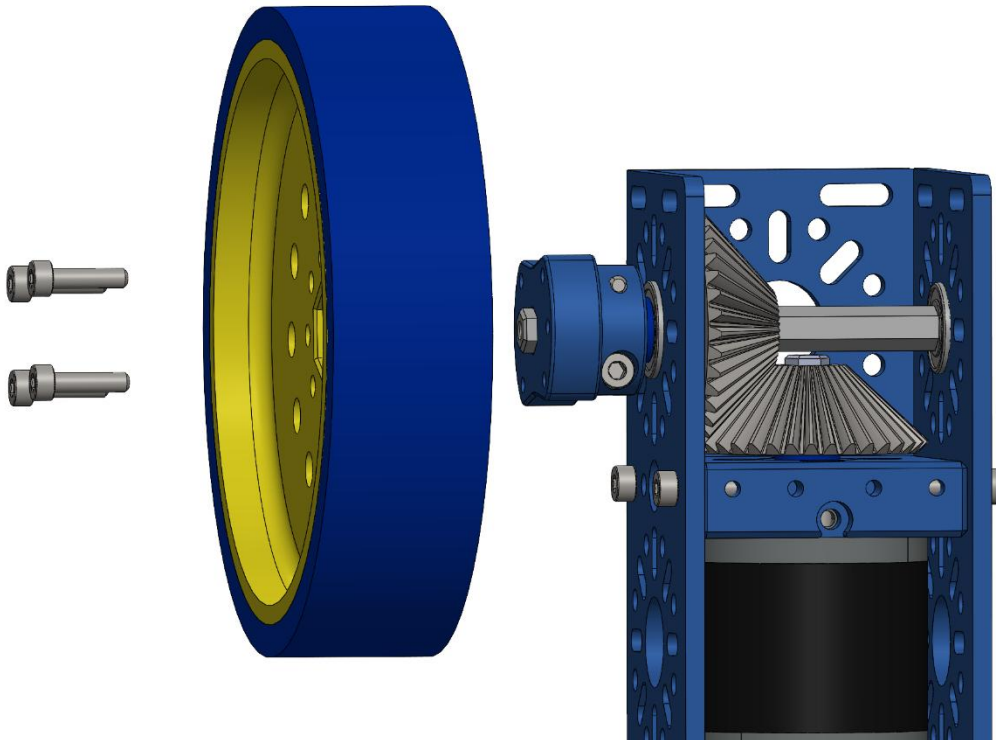

Screw the drive wheel with the M3 x 12mm SHCS into the clamping shaft hub of the drive assembly. Repeat for the other wheel on the other side of the robot.

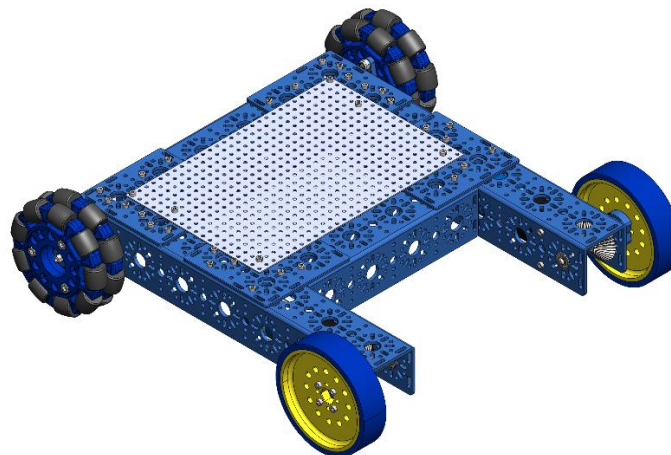

## Step 15:

Parts:

- 1 x Drive Base Assembly
- 2 x Inside L Bracket
- 4 x M3 x 10mm SHCS
- 4 x M3 Nyloc Nuts
- 1 x 2.5mm Hex Key (Green)
- 1 x 5.5mm Nut Driver

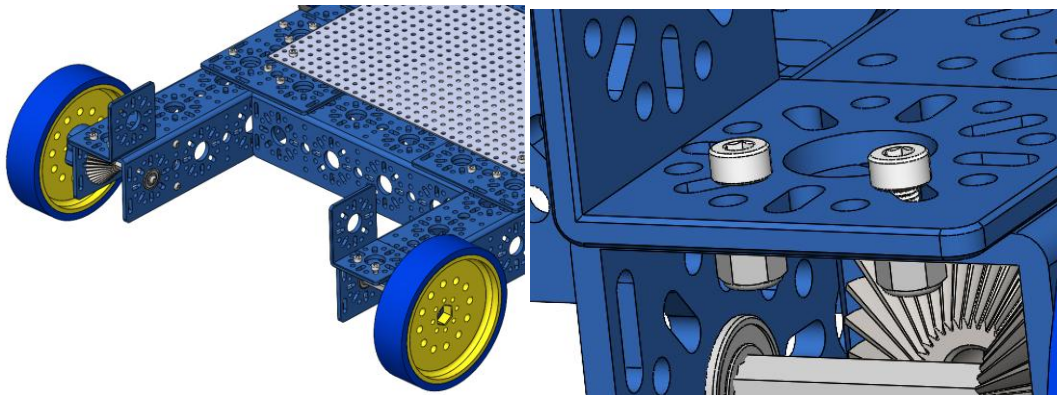

To each side of the drive base, fasten an inside L bracket facing inwards using 2x M3 x 10mm SHCS and 4 x M3 Nyloc Nuts. Ensure that the face of the L bracket is not flush with the drive base and is mounted using the corresponding slots on the u channel as shown in the images.

## Step 16:

Parts:

- 1 x Drive Base Assembly
- 1 x 288 low profile U-Channel
- 1 x Servo Standard Front
- 2 x 3 mm Screw Spacers
- 4 x M3 x 12 mm SHCS
- 4 x M3 Nyloc
- 1 x 2.5mm Hex Key (Green)
- 1 x 5.5mm Nut Driver

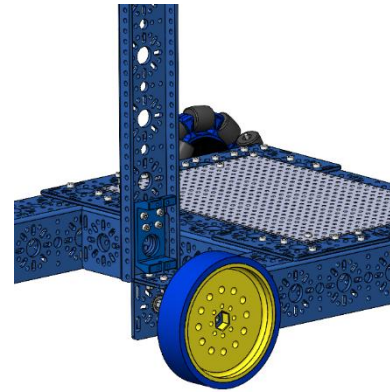

Attach a 288 low profile U channel and the servo mount together on the right side of the robot closest to the drive wheels using the parts shown below. Notice that the low-profile u channel is flush to the drive base.

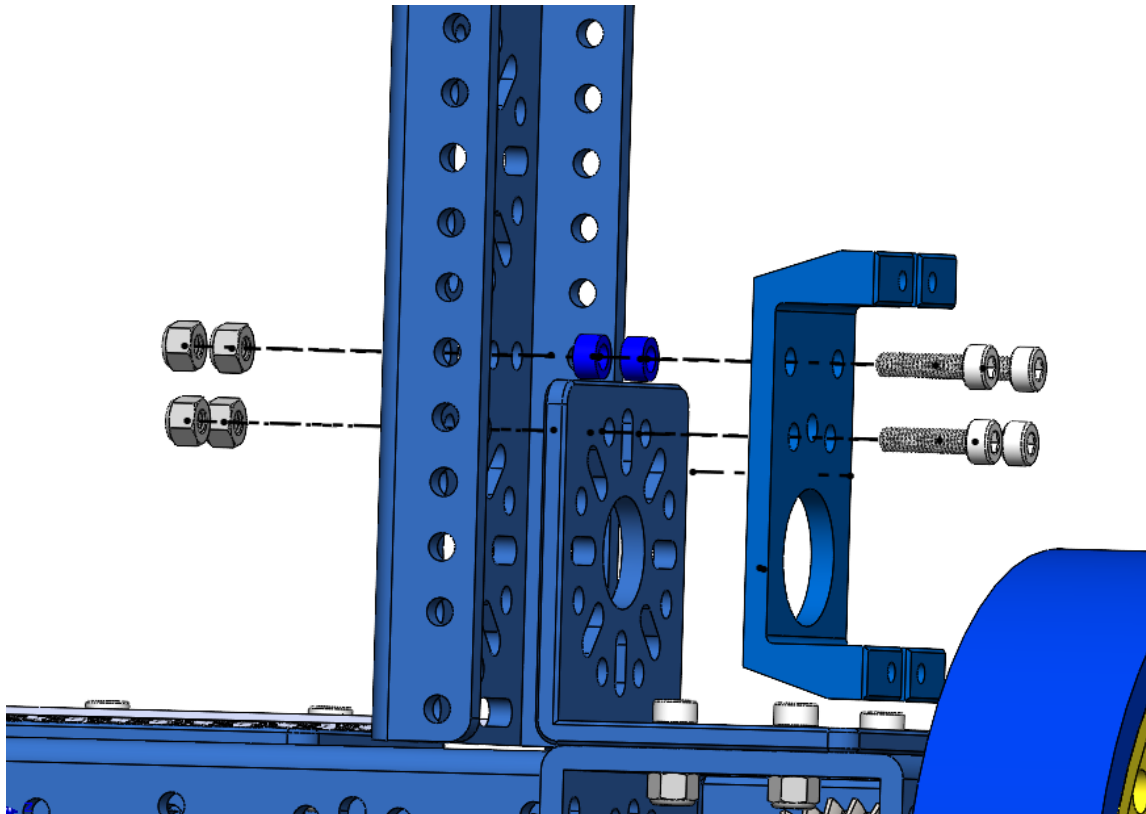

## Step 17:

Parts:

- 1 x Drive Base Assembly
- 1 x 288 low profile U-Channel
- 4 x M3 x 10 mm SHCS
- 4 x M3 Nyloc
- 1 x 2.5mm Hex Key (Green)
- 1 x 5.5mm Nut Driver

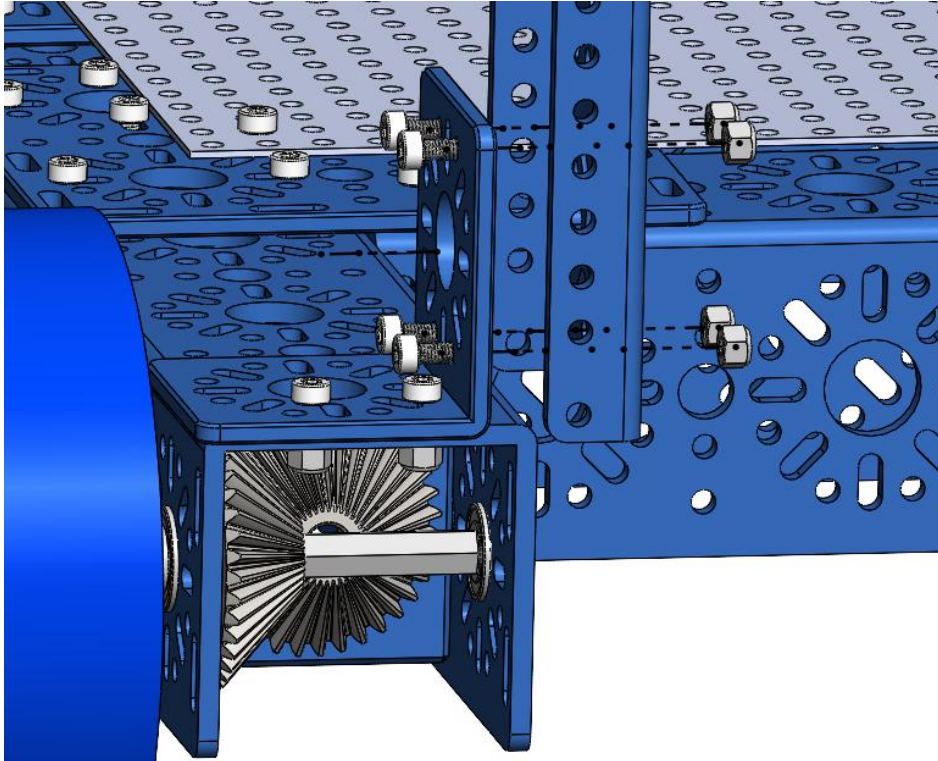

Attach another low-profile u channel to the left inside L bracket. Ensure the low-profile u channel is flush to the drive base.

## Step 18:

Parts:

- 1 x Drive Base Assembly
- 2 x Inside L Bracket
- 8 x M3 x 10 mm SHCS
- 8 x M3 Nyloc
- 1 x 2.5mm Hex Key (Green)
- 1 x 5.5mm Nut Driver



Attach an inside L bracket to the top of each 288 mm low profile u channel using a set of 4 M3 SHCS and M3 Nyloc Nuts. Notice that the L brackets are not flush to the top of the 288mm low profile u-channel as shown below.



## Step 19:

Parts:

- 1 x Drive Base Assembly
- 1x 192 mm low profile U-Channel
- 8 x M3 x 10 mm SHCS
- 8 x M3 Nyloc
- 1 x 2.5mm Hex Key (Green)
- 1 x 5.5mm Nut Driver

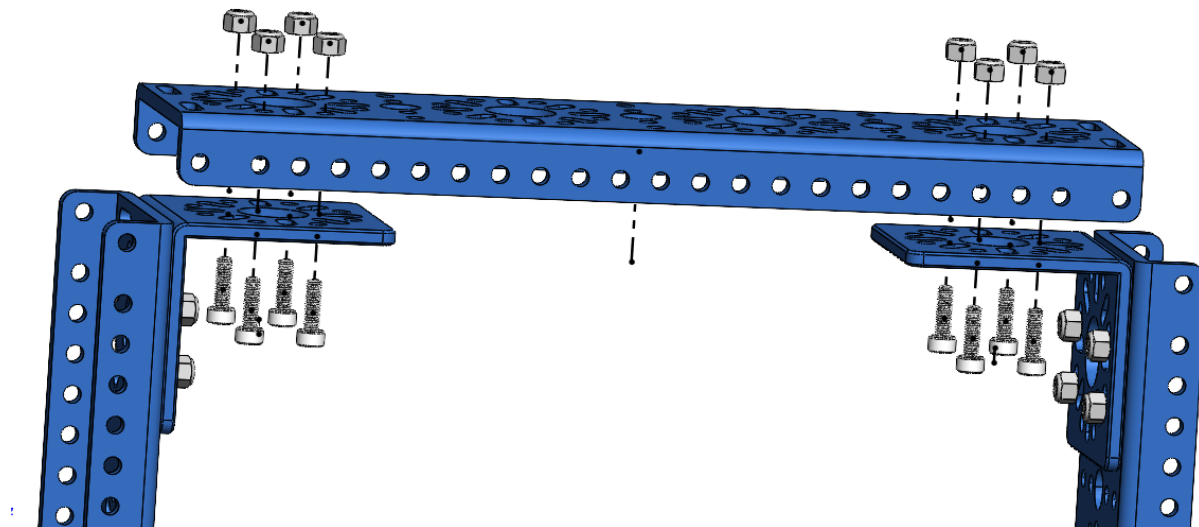

Attach the 192 mm low profile U-Channel to the top of the two inside L brackets using M3 Screws and Nyloc Nuts. The top of the channel should sit flush to the 2x 288 low profile u channels as shown below.

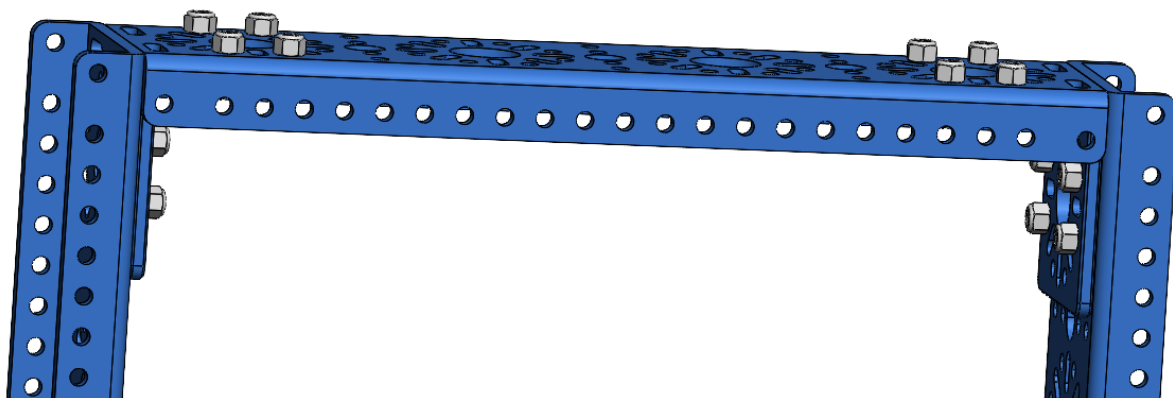

## Step 20:

Parts:

- 1 x Drive Base Assembly
- 5 x M3 x 8 mm SHCS
- 1 x Multi Mode Smart Servo
- 1x 6mm Hex Shaft Servo Hub 25T
- 1 x 2.5mm Hex Key (Green)
- 1 x 5.5mm Nut Driver
- 1 x 2.0mm Hex Key (Pink)

First assemble the 6mm Hex Shaft Servo Hub by attaching the given set screw using a 2.0 mm Hex Key. Next attach the Hex Shaft Servo hub using an 8 mm SHCS.

Once the servo assembly is finished, attach it to the bottom servo standard front mount closest to the drive base. Use 4x M3 x 8 mm SHCS.

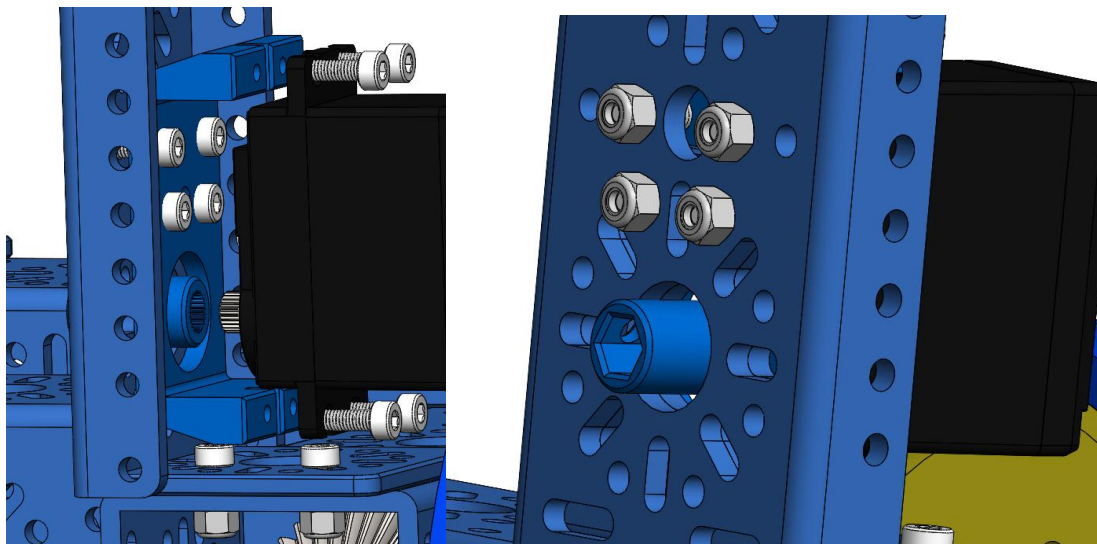

## Step 21:

Parts:

- 1 x Drive Base Assembly
- 4 x M3 x 8 mm SHCS
- 1 x Multi Mode Smart Servo
- 1x 6mm Hex Shaft Servo Hub 25T
- 1 x 2.5mm Hex Key (Green)
- 1 x 5.5mm Nut Driver
- 1 x 2.0mm Hex Key (Pink)
- 1 x Servo Standard Front
- 4 x M3 x 10 mm SHCS
- 4 x M3 Nyloc Nuts

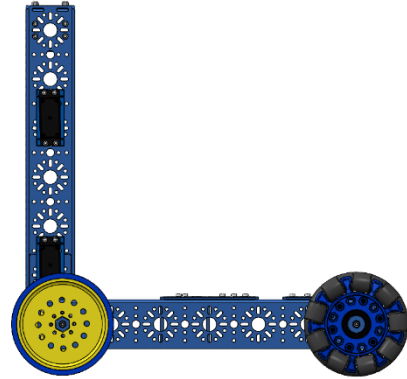

Mount a second servo standard front mount to the 4th 14 mm hole up from the bottom of the 288mm low profile U-Channel using 4x M3 x 10 mm SHCS and 4 x M3 Nyloc Nuts.

Then assemble the 6mm Hex Shaft Servo Hub by attaching the given set screw using a 2.0 mm Hex Key. Next attach the Hex Shaft Servo hub using an 8 mm SHCS.

Once the servo assembly is finished, attach it to the servo standard front mount using 4x M3 x 8 mm SHCS.

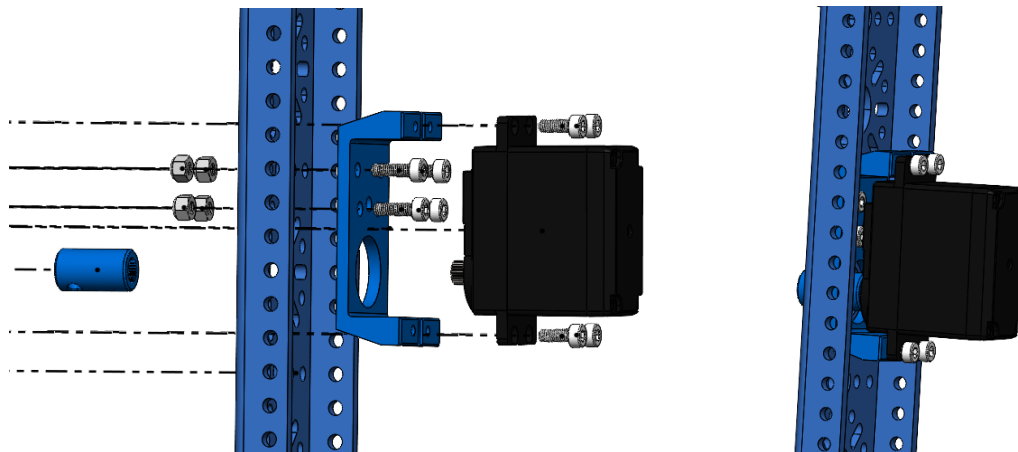

## Step 22:

Parts:

- 1 x 2.0mm Hex Key (Pink)
- 1 x 3.0mm Hex Key (Blue)
- Zip Ties, Blue, 150mm (100 pack)
- Silicone Rubber Tubing
- 8 x Intake Hex-Shaft Hub Kit



First, assemble 8 intake hubs with the set screw that are given in the Intake Hex-Shaft Hub Kit. Cut 24x Silicone rubber tubing into the length 25 mm and 24x more tubing into the length 50mm. Then attach each tube to the Intake Hub kit to make 4 total intake hubs with 25 mm tubes and 4 total intake hubs with 50 mm tubes.

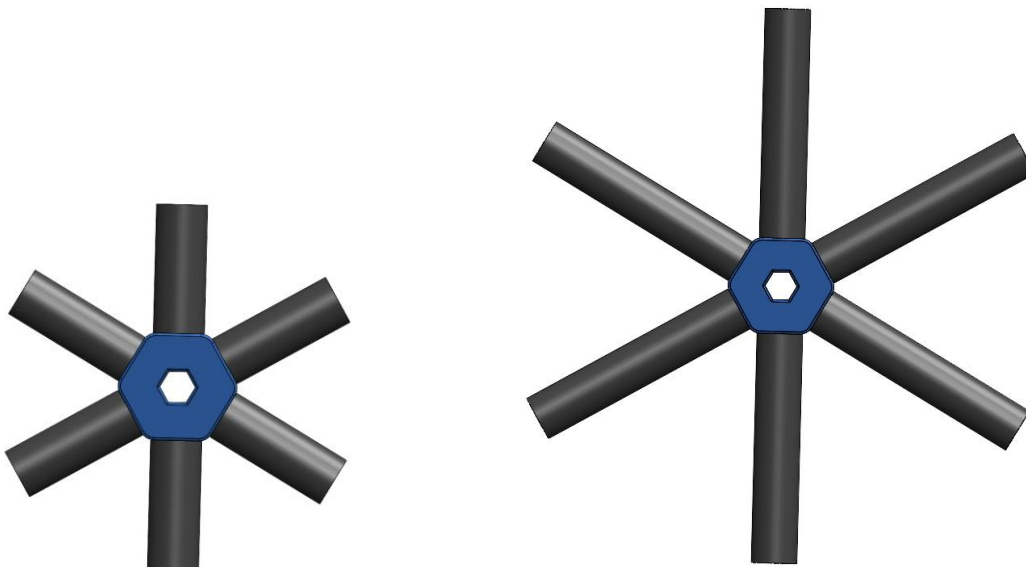

## Step 23:

Parts:

- 1 x Drive Base Assembly
- 2x 50mm Tubes Intake Hub Assembly
- 2x 25mm Tubes Intake Hub Assembly
- 2x 96mm Hex Shaft
- 1 x 2.0mm Hex Key (Pink)

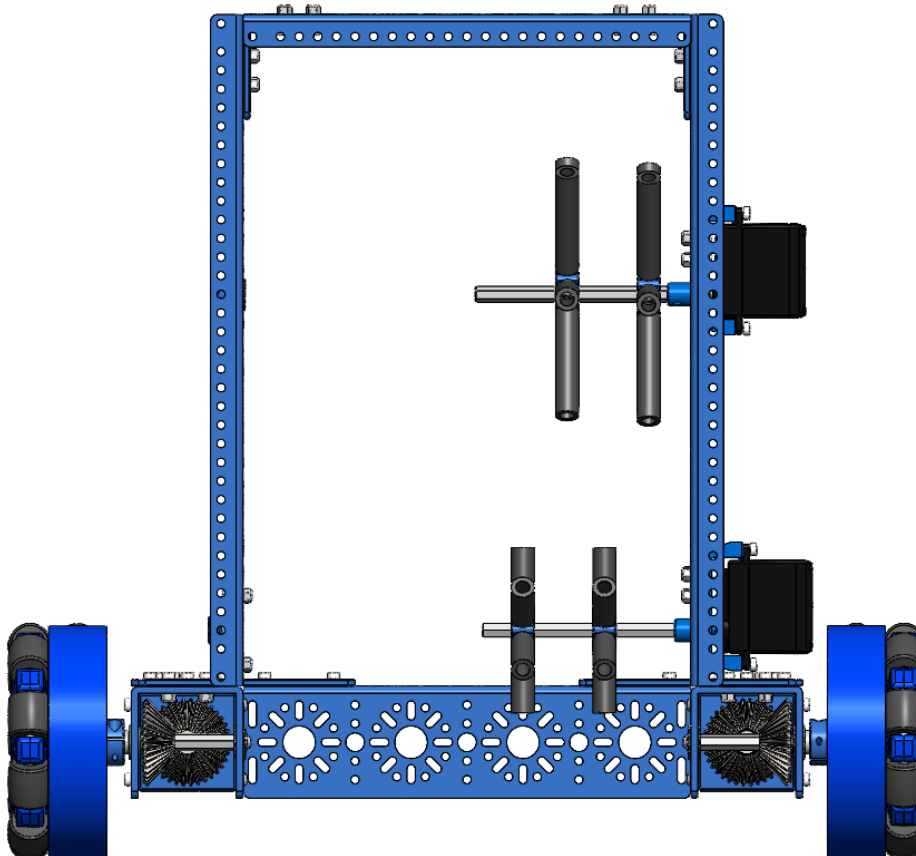

Use the 2.0mm Hex Key (Pink) to mount 2x 96mm hex shafts into the two Hex Shaft Servo hubs. Slide and attach the 2x 50 mm Tubes intake hubs on top roller. Mount 2x 25 mm Tubes intake hubs on the bottom roller.

## Step 23:

Parts:

- 1 x Drive Base Assembly
- 2 x 6mm Hex-Shaft Coupling 12mm OD
- 1 x 2.0mm Hex Key (Pink)

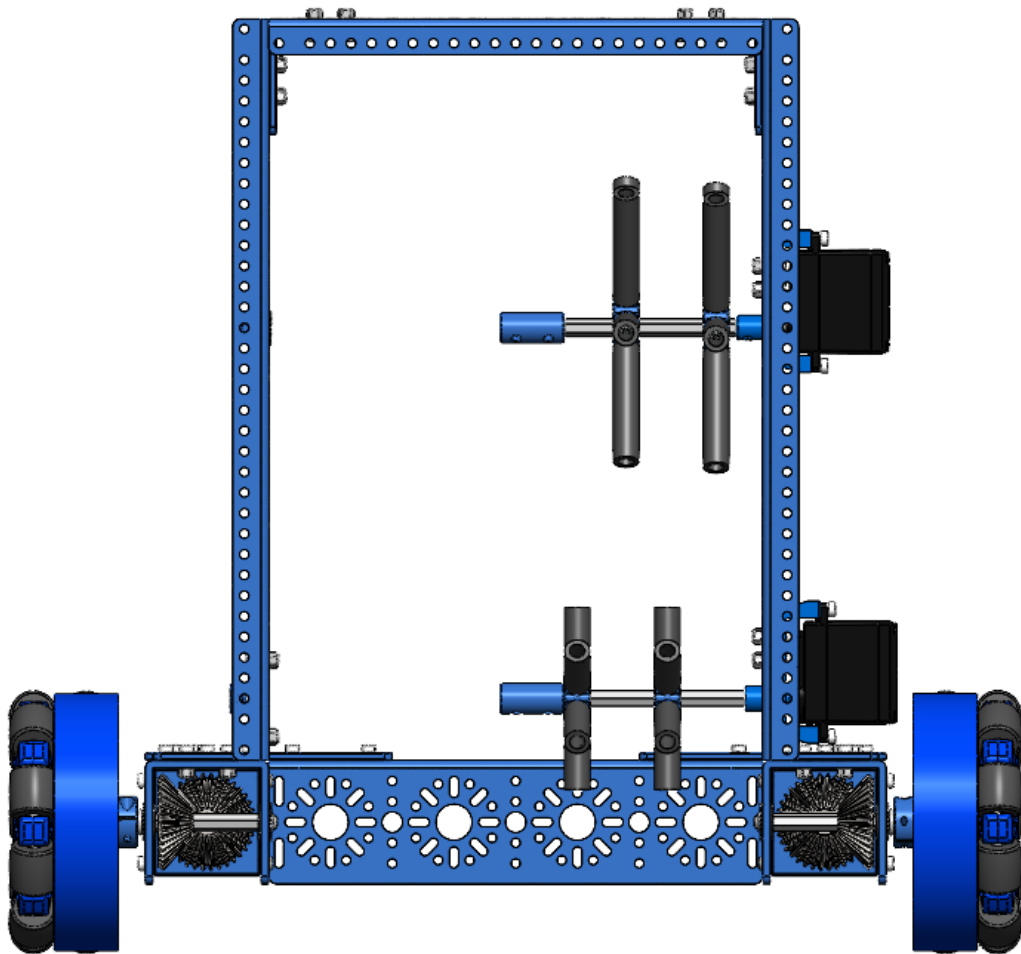

Attach two 6mm Hex-Shaft Coupling 12mm OD by tightening the set screw using a 2.0mm Hex Key (Pink) as shown above. Ensure that only half of the coupling is attach to each 96mm Hex shaft as the other end will be fastened to another shaft in the latter steps.

## Step 24:

Parts:

- 1 x Drive Base Assembly
- 2x 50mm Tubes Intake Hub Assembly
- 2x 25mm Tubes Intake Hub Assembly
- 2x 140 mm Hex Shaft
- 1 x 2.0mm Hex Key (Pink)

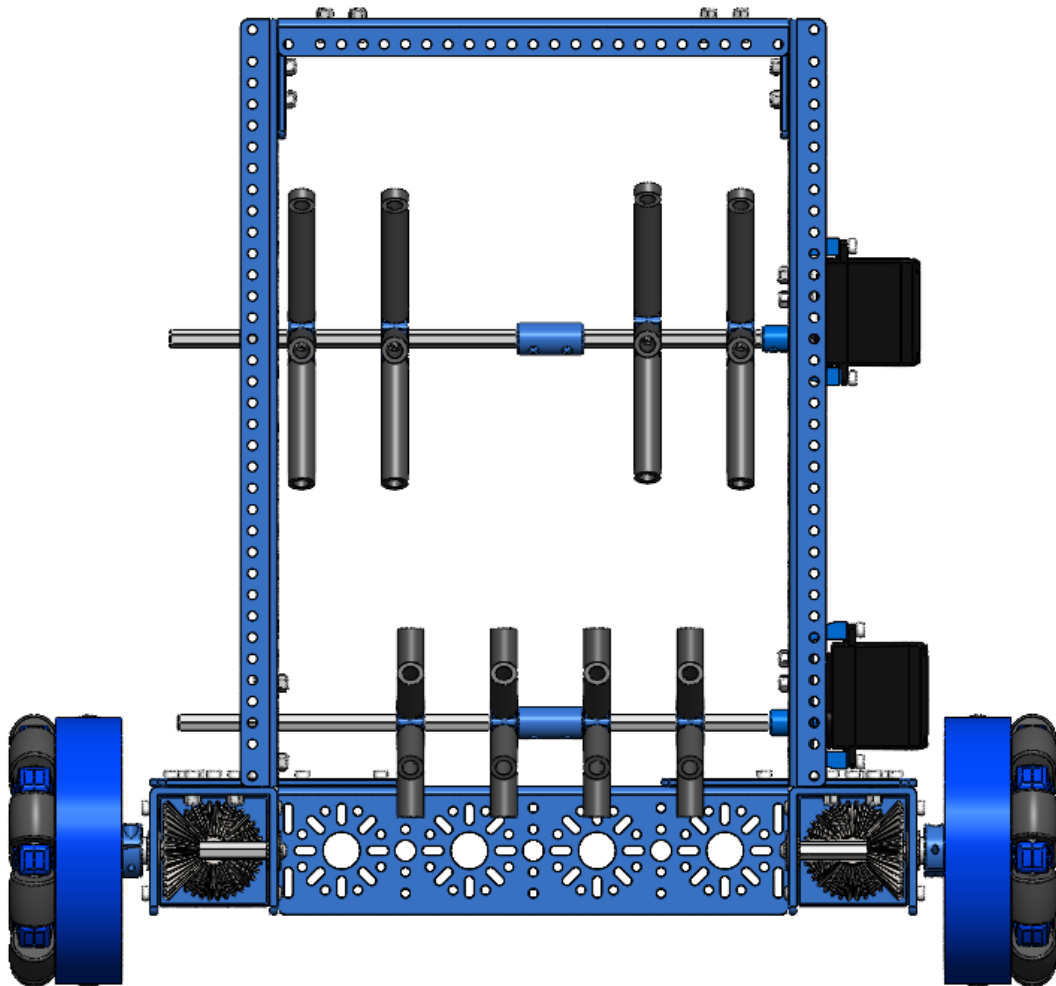

Loosely slide in 2x 140mm hex shafts into the two 6mm Hex-Shaft Coupling 12mm OD. Slide and attach the 2x 50 mm Tubes intake hubs on top roller shaft. Mount 2x 25 mm Tubes intake hubs on the bottom roller shaft. Once placed like shown in the image above, please fasten each intake hub and shaft using the 2.0mm Hex Key (Pink).

## Step 25:

### Parts:

- 1 x Drive Base Assembly
- 2 x 6mm Hex Shaft Flanged Bearing
- 1 x 2.0mm Hex Key (Pink)
- 2 x 6mm Hex Shaft Spacer 2mm, Nylon
- 2 x 6mm Hex Shaft ID x 12mm OD Collar

Secure both rollers by sliding in a 6mm Hex Shaft Flanged Bearing with the flange facing the outside and then slide a 2mm hex spacer. Finally fasten the shaft assemblies using 6mm Hex Shaft ID x 12mm OD Collar and tighten the collars' set screws using a 2.0mm Hex Key (Pink).

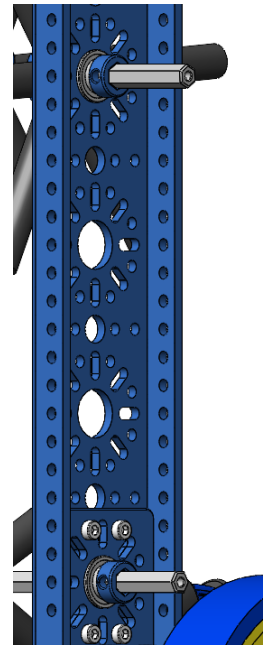

**This completes the build guide for the 2026 / 2027 Starterbot from Studica.  
Good luck with your season!**